



March 2022

NYC Parks GreenThumb Community Garden Accessibility Guide

Table of Contents

GreenThumb Overview	4
Community Engagement	4
Operations	4
Planning and Programs	4
How to Read the NYC Parks GreenThumb Community Garden Accessibility Guide	5
Background	5
Reach Ranges	6
Pathways	7
Dimensions	7
Slope	8
Obstacles, Hazards, and Clearance	8
Corners	8
Materials	9
Diamond Grid Path	9
Diamond Grid Maintenance:	10
Crushed Stone Path	11
Crushed Stone Path Maintenance:	12
Paver Path	13
Paver Path Maintenance:	14
Raised Beds	15
Circulation	15
Materials	15
Wood or Block Raised Beds	15
Container Gardening	15
Types of Raised Beds	16
Tabletop Raised Beds	16
Dimensions	16
Tips	17
Elevated Side-Access Bed	18
Dimensions	18
Trellises	19
Arbors	19
Espalier	20
Picnic Tables	21

Sheds	23
Dimensions	23
Entrance	23
Inside the shed	23
Shed Location	24
Tool Shed Modifications	24
Ramps	25
Handrails	26
Irrigation	27
Communication	27
Examples of Accessible Gardens	28

GreenThumb Overview

NYC Parks GreenThumb is proud to be the nation's largest urban gardening program, assisting over 550 gardens and over 20,000 volunteer gardeners throughout New York City on 100 combined acres of open space. GreenThumb gardens create hubs of neighborhood pride while providing a myriad of environmental, health, economic, and social benefits to the neighborhoods in which they thrive. Additionally, GreenThumb supports a growing network of over 750 school gardens through the Grow to Learn citywide school garden initiative.

The majority of GreenThumb gardens were abandoned lots transformed by volunteers into green spaces for relaxation, socializing, and growing food, or a combination. These community gardens are managed by neighborhood residents with GreenThumb support. Together GreenThumb and community gardeners make the city safer, healthier, stronger, and more sustainable.

GreenThumb's mission is to support New Yorkers to strengthen their neighborhood through community gardening by providing the resources needed to steward these valuable spaces.

GreenThumb has three teams that support gardeners and gardens:

Community Engagement

GreenThumb's Community Engagement Team is the first point of contact for our network of community and school gardens. Outreach Coordinators assist gardeners with community organizing and development. They also help garden groups with special projects and connect gardeners with a variety of available resources. In addition, our Youth Programming and School Garden Coordinator gives support to school gardens through the Grow to Learn citywide school garden initiative and administers the Youth Leadership Council, our annual volunteer program that engages youth in civic engagement and beautification projects at community gardens throughout the City.

Operations

GreenThumb Operations is our boots-on-the-ground team that provides material and operational support to both community and school gardens in addition to handling property management issues. You may find them delivering clean topsoil and lumber, preparing new garden sites for planting, making repairs, caring for trees in gardens, or inspecting conditions in gardens. The Operations team manages deliveries and seasonal supply distributions that provide gardens with the materials they need to grow.

Planning and Programs

GreenThumb's Planning and Programs Team lays the groundwork for GreenThumb's long-term success and provides gardeners access to the skills, support, and resources needed to flourish. In addition to leading GreenThumb's effort to expand our reach and impact, this team oversees the annual GreenThumb GrowTogether conference, Harvest Fair, Open Garden Day NYC, and other large events and programs. They also host 150+ workshops and numerous volunteer projects. The Planning and Programs Team implements grants and produces quarterly publications that advertise GreenThumb's programs to gardeners and the general public. They oversee data analysis and complicated projects such as new garden builds and provide a variety of services to community gardeners.

How to Read the NYC Parks GreenThumb Community Garden Accessibility Guide

We hope this guide will help the creation of inclusive community gardens where everyone can enjoy the full mental and physical benefits of urban gardening. Given the limited resources available for most community gardens, we attempt to illustrate options for accessibility that can easily be achieved without expensive equipment or cost prohibitive materials. Each chapter below contains suggested guidelines on how to make basic garden features accessible to people who use wheelchairs and other walking aids. These guidelines reflect the practices of GreenThumb but also function to communicate accessibility options that garden groups could potentially achieve without professional assistance. While this document currently focuses on mobile accessibility, we will continue to update sections as we further develop guidelines for differing abilities.

Background

This guide originally sought to define GreenThumb's current (yet ever-evolving) standards for accessibility for projects completed by our Operations Team. In our mission to support community garden capacity as well as accessibility, we ultimately hope this guide will help community gardeners build accessible gardens independently as well. The guide bases most construction recommendations included on materials that GreenThumb regularly provides for community gardens. We worked together with NYC Parks' Capital Projects Accessibility Coordinator Christopher Noel to ensure that these guidelines align with Parks' criteria for mobile accessibility.

Reach Ranges

The following lay out the dimensions that need to be considered when designing for gardeners and garden visitors who use wheelchairs. Take these reach ranges into consideration when building pathways, raised beds, social areas, and arches from which garden members might pick fruit.

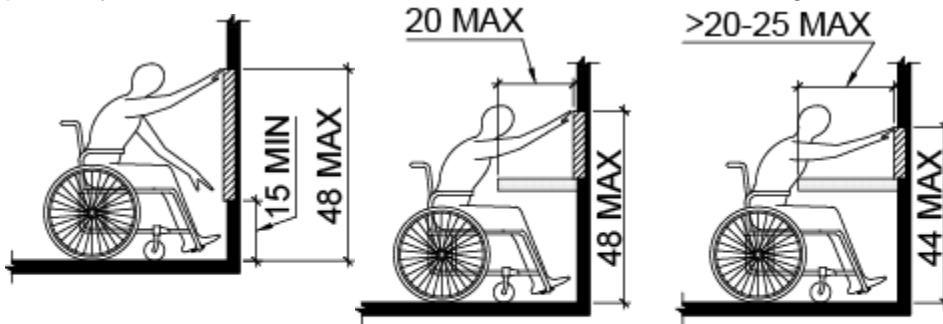

UNOBSTRUCTED FORWARD REACH

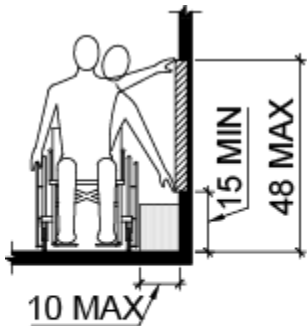

UNOBSTRUCTED HIGH FORWARD REACH

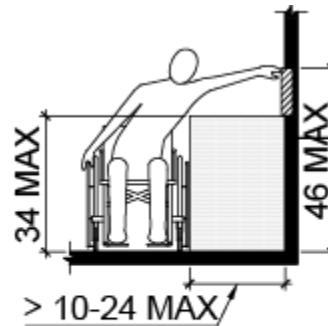
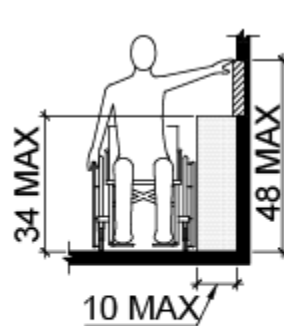

UNOBSTRUCTED SIDE REACH

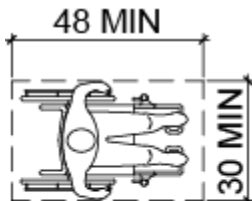

UNOBSTRUCTED HIGH SIDE REACH

CLEAR FLOOR

Pathways

Dimensions

Pathways in accessible areas should be no less than 48". When this is impossible, paths should be a minimum of 36" with turning platforms of 60" width or T intersections every 200'¹.

At a gateway, 32" wide paths are passable. Portions that are 32" wide should not go longer than 24".

60" width is the minimum needed to allow for U-turns and two wheelchairs passing each other.

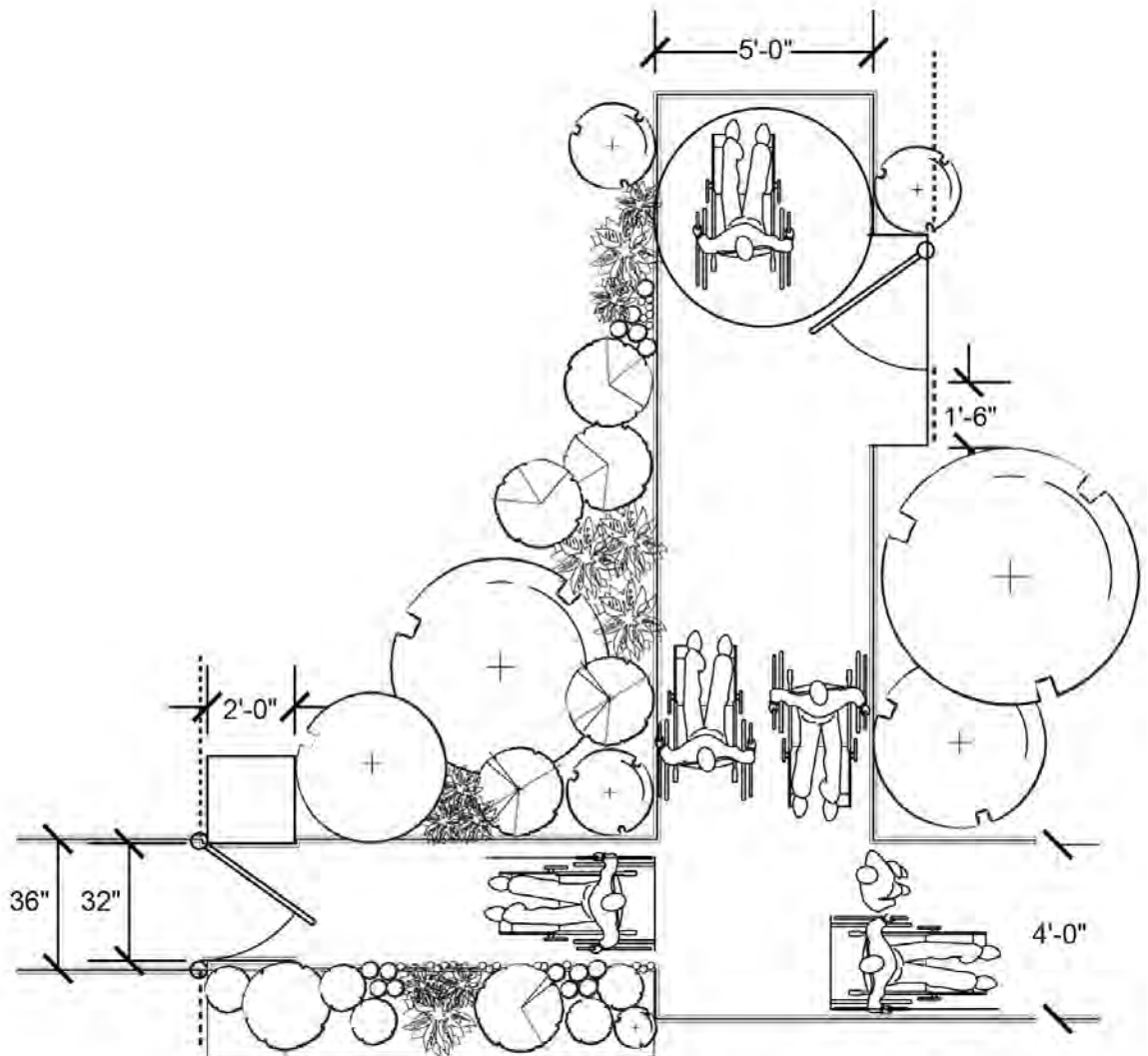
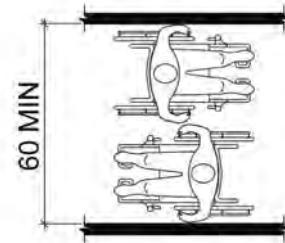
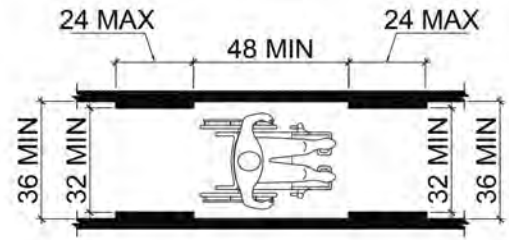

¹ Clearances [§403.5] <https://www.access-board.gov/guidelines-and-standards/buildings-and-sites/about-the-ada-standards/guide-to-the-ada-standards/chapter-4-accessible-routes>

Slope

The slope in the direction of travel must be no steeper than 1:20 (1' rise in 20') or 5% maximum. This means that for every 1 inch of height, there must be 20 inches of path length.

There also must be a cross slope maximum of 2% or 1:48. The cross slope is the slope going across the path that is perpendicular to the direction of travel. For example, if for every 24 inches in length, you have at .5 inches in height, then your cross slope is accessible.

Cross-slopes greater than this can cause slides and skids, loss of control and balance, unequal hand-braking.

Where conditions dictate a slope greater than 5%, a ramp must be provided (see [Ramp section](#) for specifications).

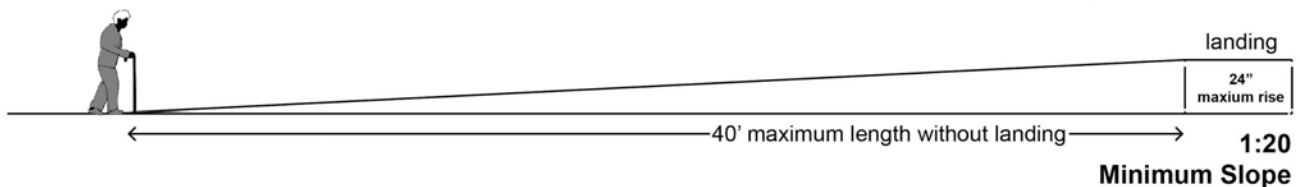

There should be no grade change between roadway and garden entrance unless ramps and curb cuts are used.

Obstacles, Hazards, and Clearance

It is important that garden groups actively keep all garden paths and spaces clear of any hazards or items such as hoses or debris that can impede access by people who use wheelchairs or other mobility aids. Even if you build your path with following accessibility guidelines for dimensions, slope, and materials, it will still be inaccessible if there are items blocking the way that cannot be moved easily.

Corners

If possible, it is a good idea to incorporate path turns that have gradual, easy curves, instead of sharp corners. This may be more difficult if you build your path with large paver stones but easier if you use stone dust, pea gravel, or smaller paver stones or bricks.

Materials

Diamond Grid Path

1. Prepare the area by digging 6" deep where the diamond grid will be placed.
2. Compact down soil with a hand tamper or plate compactor. Ensure area is level as shown in Figure 1.
3. Place landscape fabric over compacted soil
4. Place desired edging at edges of prepared area. You can use lumber, stone, or special plastic or steel as edging.
5. Pour and spread gravel over the landscape fabric. This will be the foundation of your path, as shown in Figure 2. Gravel foundation should consist of 4" of $\frac{3}{4}$ " or $\frac{5}{8}$ " crushed concrete or decomposed granite.
6. Compact down gravel with a hand tamper or plate compactor. Ensure area is level.
7. Cut diamond grid to desired width to fit path.
8. Lay the diamond grids starting in one corner with the male lugs facing outwards on both male sides as shown in Figure 2.
9. Fill the diamond grid with pea gravel or your choice of material-dirt, gravel, woodchips, or stone dust as shown in Figure 3. Compact material with hand tamper or plate compactor and continue to sweep in material as shown in Figure 4.



Figure 1



Figure 4



Figure 3



Figure 2

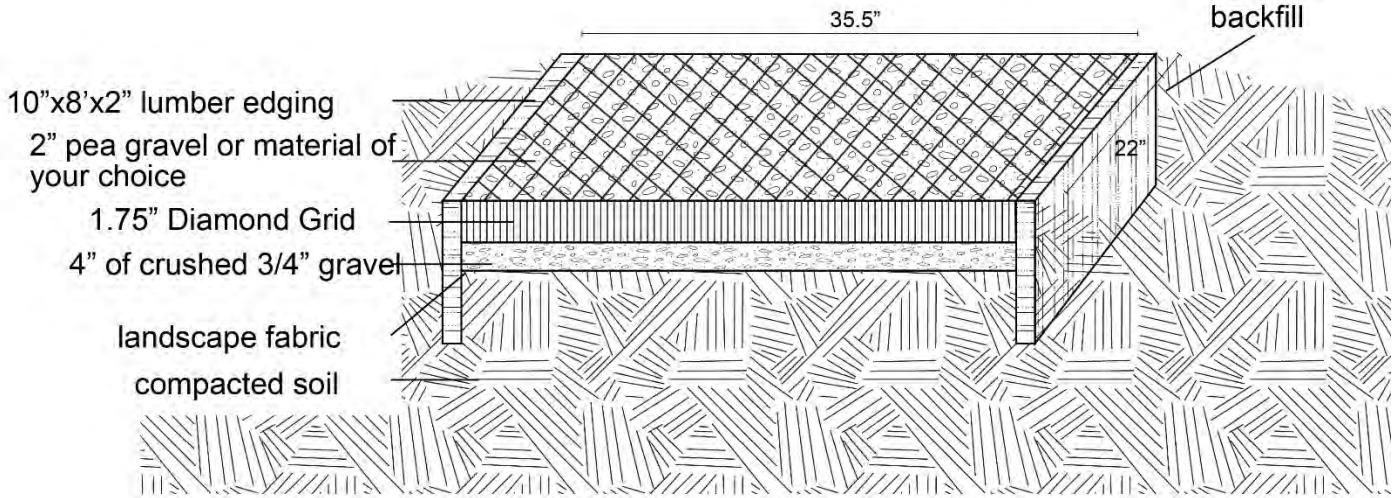

Diamond Grid Maintenance:

Diamond grids may still require replenishing materials every 2 years or as needed as gravel or fill material settles and compacts within the grid.

Crushed Stone Path

1. Prepare area by digging at least 6" below current level.
2. Compact down soil with a hand tamper or plate compactor. Ensure area is level.
3. Place landscape fabric over compacted soil.
4. Place desired edging at edges of prepared area. You can use lumber, stone, or special plastic or steel as edging as shown in Figure 5.
5. Pour and spread gravel over the landscape fabric. This will be the foundation of your path, as shown in Figure 6. Gravel foundation should consist of 4" of $\frac{3}{4}$ " or $\frac{5}{8}$ " crushed concrete or decomposed granite.
6. Compact down to 90 - 95% with a hand tamper or plate compactor. Ensure area is level.
7. Using a rake, spread 2" of $\frac{1}{4}$ " or $\frac{3}{8}$ " crushed stone evenly on gravel foundation. Angular particles like andesite, dolomite, and certain types of granite can easily be wetted and compacted to meet the recommended standards of the Americans with Disabilities Act Accessibility Guidelines.
8. Wet the crushed stone and compact with a hand tamper or plate compactor as shown in Figure 7.



Figure 5



Figure 6



Figure 7

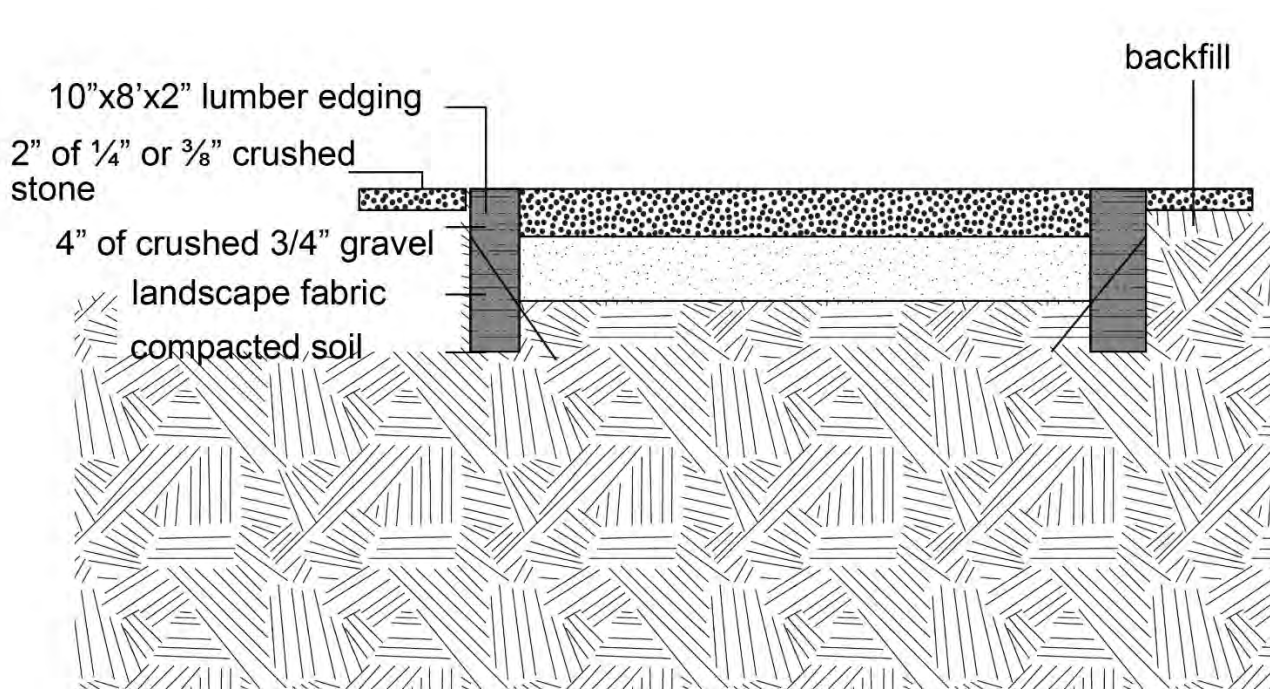

Crushed Stone Path Maintenance:

Annual maintenance includes weeding. Additional material may be needed every five years. If the surface of a crusher fines trail becomes loose and uncompacted over time it can often be wetted, reshaped and recompactd.²

² <https://www.americantrails.org/resources/the-art-of-building-crushed-stone-trails>

Paver Path

1. Prepare the area by digging at least 4" plus the thickness of the paver stones.
2. Compact down soil with a hand tamper or plate compactor. Ensure area is level.
3. Place landscape fabric over compacted soil.
4. Place desired edging at edges of prepared area. You can use lumber, stone, or special plastic or steel as edging.
5. Pour and spread gravel over the landscape fabric. This will be the foundation of your path. Gravel foundation should consist of 4" of $\frac{3}{4}$ " minus or $\frac{5}{8}$ " minus crushed concrete or decomposed granite.
6. Compact down gravel with a hand tamper or plate compactor. Ensure area is level. You can slightly pitch the gravel in one direction to allow water to run off the pavers but check the area with a level to be sure that area does not drop more than slope and cross slope requirements allow.
7. Spread 1" of paver sand over compacted gravel.
8. Screed sand: Place 2 parallel 1" PVC pipes or 1"x1" pieces of lumber at 4' max. distance. Pour 1" of paver sand over them. Use another piece of PVC or lumber (a screed-er) to lay over the two parallels. Run the screed-er along the parallels to smooth out the sand. Fill any holes and make sure the sand is perfectly level and following your desired pitch by using a level.
9. Lay pavers: Lay pavers on sand. Once the pavers are where you want them, tap them with a mallet and check with a level.
10. Gaps between pavers can only be $\frac{1}{2}$ " maximum, joints between the pavers should be firm and stable enough that a wheel would not get stuck. Watch for changes in Level $\frac{1}{4}$ " to $\frac{1}{2}$ " max depending on if it has a bevel. Brush polymeric sand between the cracks of the pavers.
11. Hose down pavers to activate polymeric sand.



Figure 6



Figure 7



Figure 8

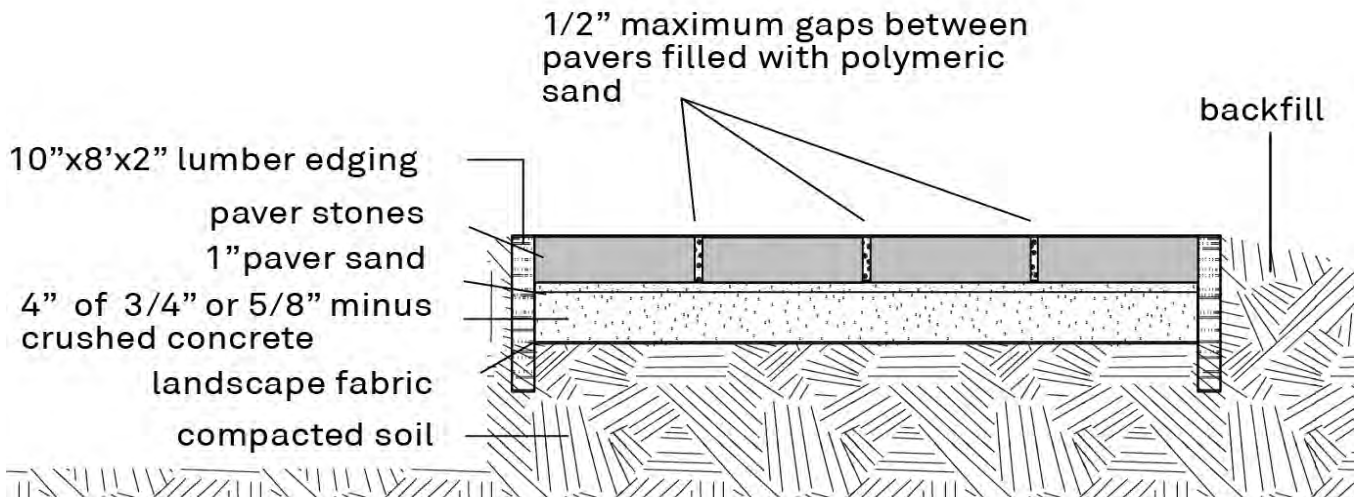

Paver Path Maintenance:

Annual maintenance includes weeding. Subsidence or sinking may occur after a number of years or if the base material is not compacted sufficiently or if the ground settles over an extended period of time. If this happens, the pavers must be taken out and reinstalled properly.

Raised Beds

Circulation

Accessible beds should be reachable along wheelchair-accessible pathways from entrance, near tool storage, and adjacent to a water station.

Materials

Wood or Block Raised Beds

Many gardens have built tall planter boxes out of wood. Cinder blocks, landscape edging blocks, stone, bricks, and poured concrete are other choices.



Wishing Well Community Garden



Powers Street Community Garden



Container Gardening

Pots, stacked milk crates, or other recycled containers are another way to achieve accessible gardening. If you use this method, make sure your planter is at between 20"-34" high and 10"-24" wide. You can add bricks, stones, or some other platform to achieve this height if needed.

Types of Raised Beds

Tabletop Raised Beds

These types of beds are helpful for those with limited sight.

If this style is chosen, be aware of the following considerations. A north-south orientation for the planter is best for low-growing crops.

Dimensions

Raised beds should be:

- between 20"-34" high and 10"- 24" wide.
- If the bed is accessible from 2 sides, the bed can be a maximum of 48" wide.
- There should be 27" knee clearance for table-top style beds.
- There are several ways to create tabletop gardens, but the dimensions above should be followed regardless of the bed's design.

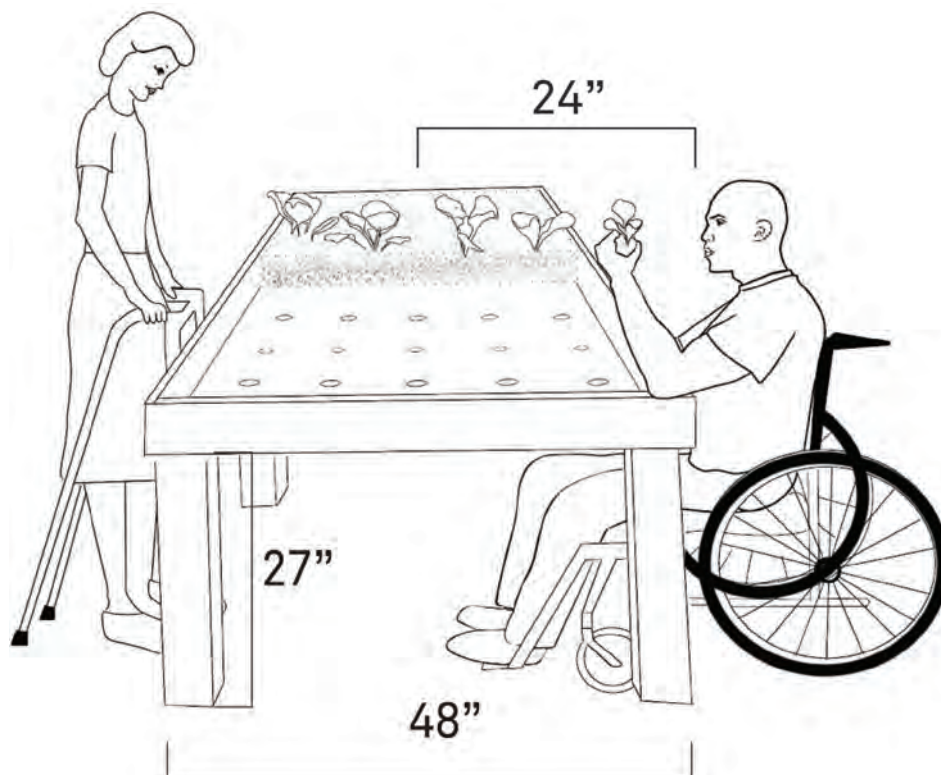
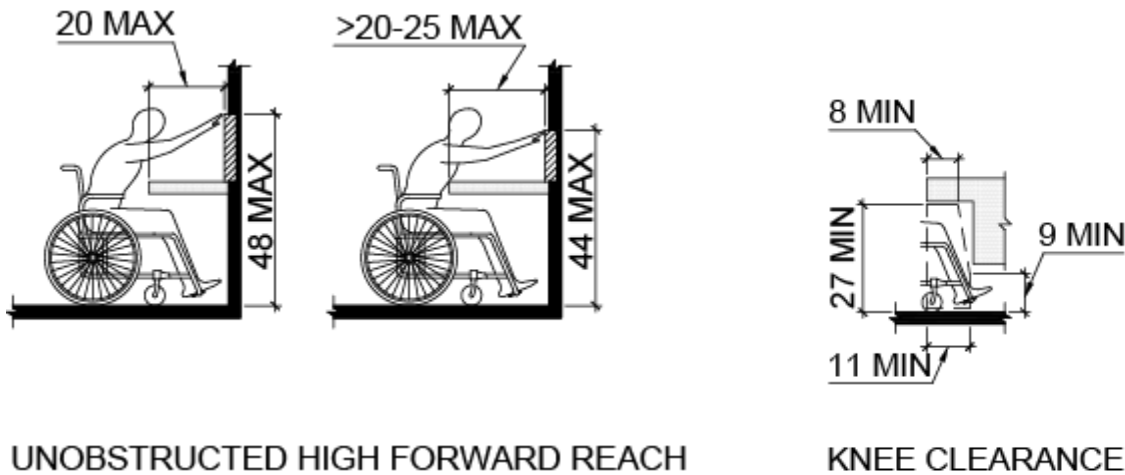

Tips

Drilling 1/2-" holes every 6" across the base promotes good drainage and lining the planting bed bottom with a landscaping fabric before adding the soil mix allows only the water to drain through the holes.

Secure the footings into the ground with cement for best stabilization.

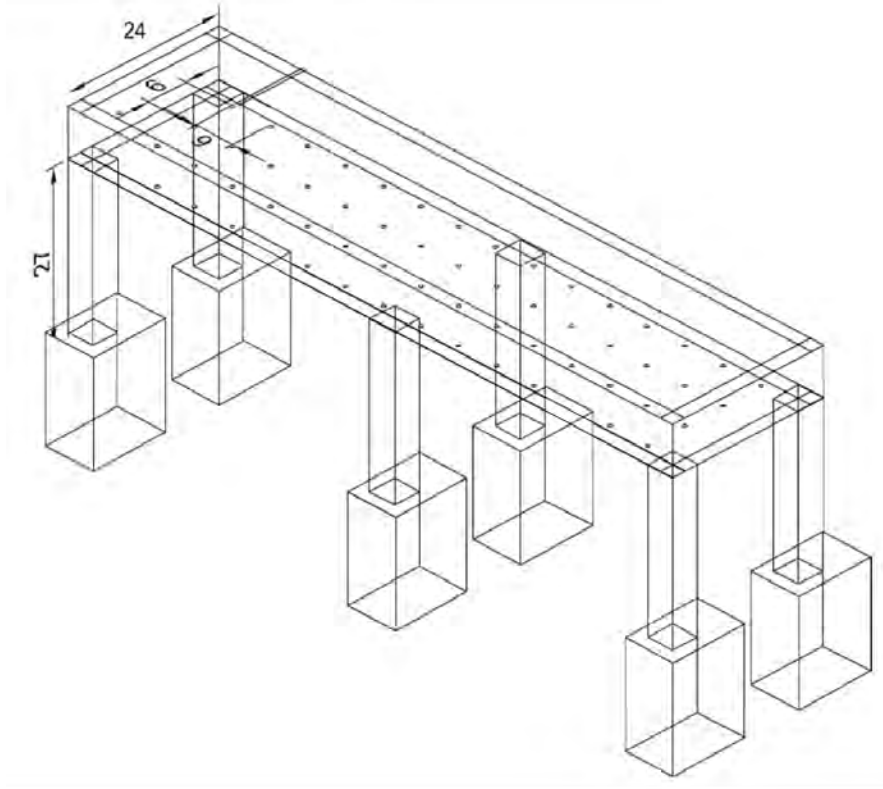

Elevated Side-Access Bed

Raised beds can also be made accessible by raising them 20" or 30" so they can be accessed from the side.

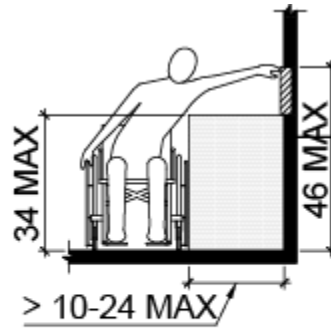
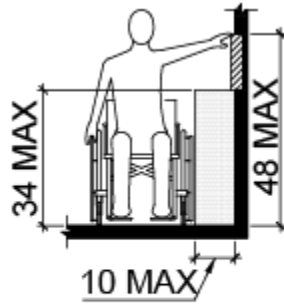
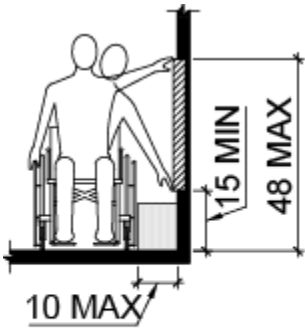

UNOBSTRUCTED
SIDE REACH

UNOBSTRUCTED HIGH SIDE REACH

Dimensions

Raised beds should be between 20"-34" high and 10"-24" wide. Again, if the bed is accessible from two sides, the bed can be a maximum of 48" wide.

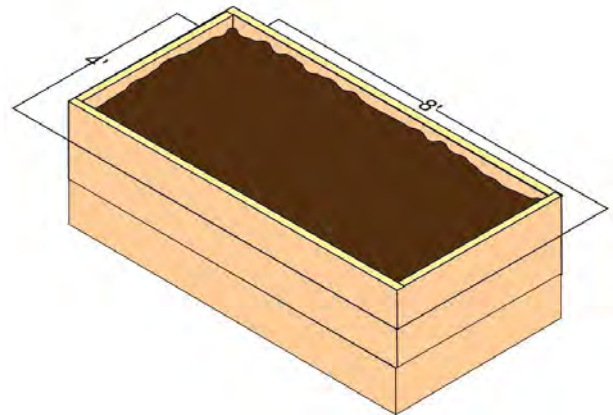
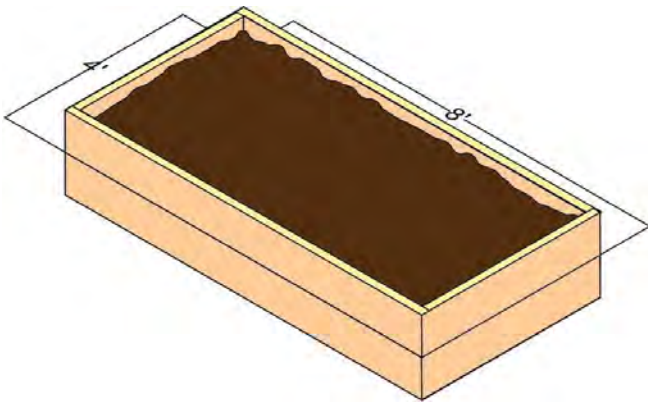

Trellises

Vining plants can be grown in as little as 5-gallon containers or planters that are 10" wide to allow for larger side reach range.

Using a trellis brings the plants within easy reach. Wire mesh trellises are recommended for cucumbers, pole beans, runner beans, and peas.

A-Frame trellises are recommended for beans, peas, gourds, melons, squash, and cucumbers.

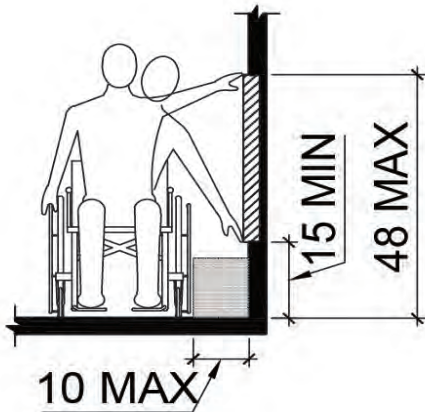

Joe Holzka Community Garden

Arbors

Arbors can be used to grow grapes as well as dwarf fruit trees like peaches, apricots, and plums as well as runner beans, pole beans, cucumbers, English peas, sugar-snap peas, small melons, vining summer squash, winter squash, and small varieties of pumpkins.

In order to allow wheelchair users to harvest from arbors, 6' max height over an accessible path is recommended. Arbors should be open both ends to allow for accessible harvesting throughout the entire structure.

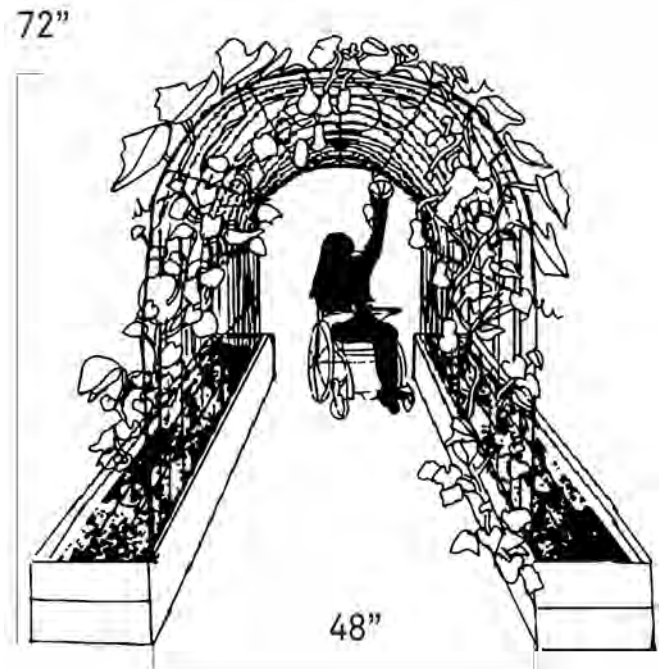

Espalier

With adequate conditions, you can use espalier techniques to grow apple, blueberry, citrus (orange, lemon, limes), kumquat, nectarine, olive, pear, plum, and quince. Placing espalier along a path allows for accessible harvesting as well as adding beauty to your garden.



Feeding Tree Community Garden

Picnic Tables

- An accessible picnic table must be connected to an accessible path.
- Picnic tables and benches must be on a surface that follows accessibility standards (see the path materials section on pages 9-14 for options).
- There must be a minimum of 36" clear space measured from the seat must be provided.
- An accessible picnic table must have at least one wheelchair seating space.
- Picnic tables and benches must have no sharp edges or hazardous objects protruding. There must be 30" width space minimum for wheelchair seating, and 27" between bottom of table to ground to allow room for knees (see Table-top Style Beds requirements on page 16)
- There must be at least 28" and 34" from the ground to the top of the table.
- Picnic tables must have a minimum knee clearance of 27" high, 19" deep, and 30" wide.
- Picnic tables must have a minimum toe clearance of 9" high and 24" deep.

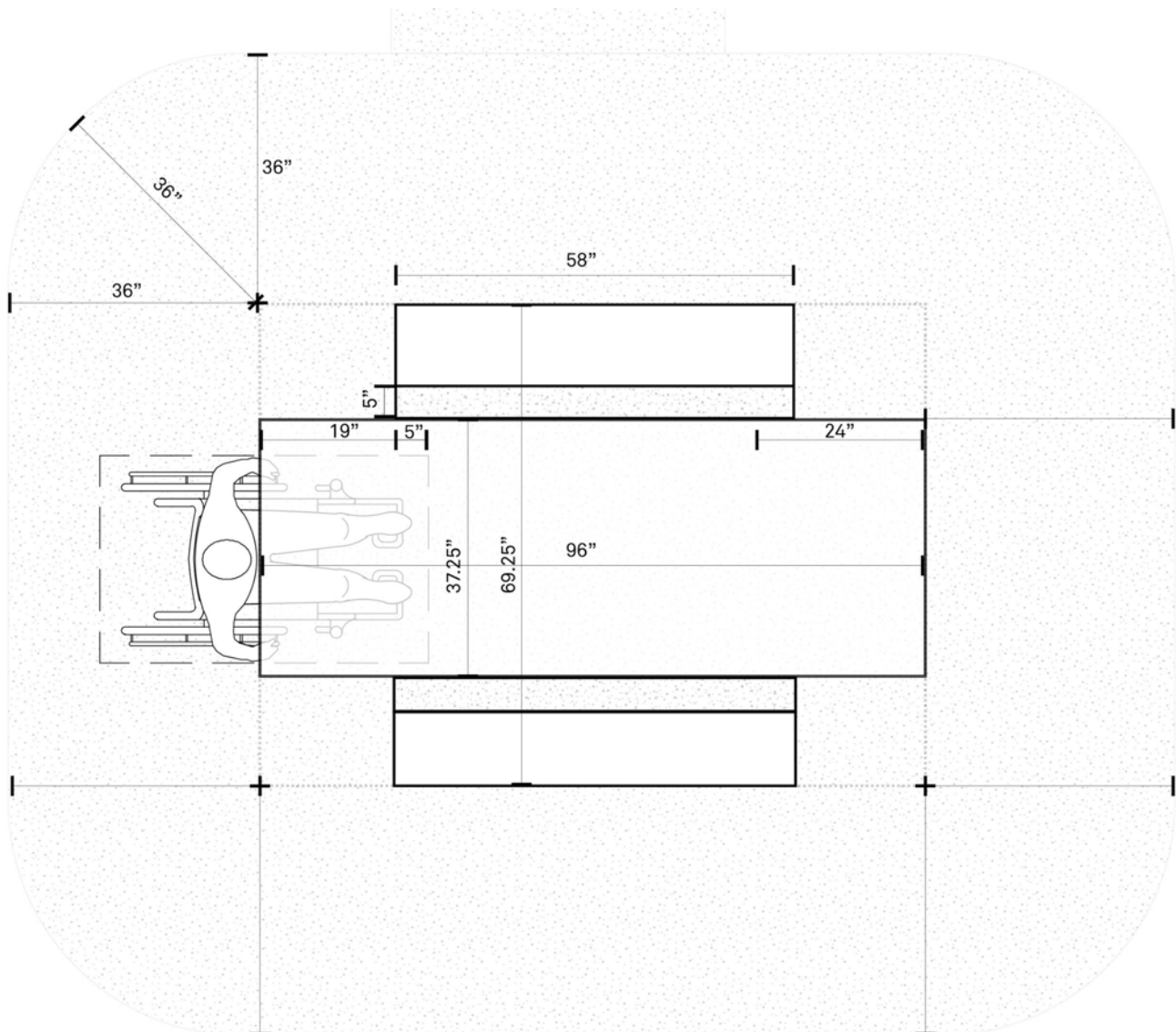

Figure 9 Plan view of accessible picnic table

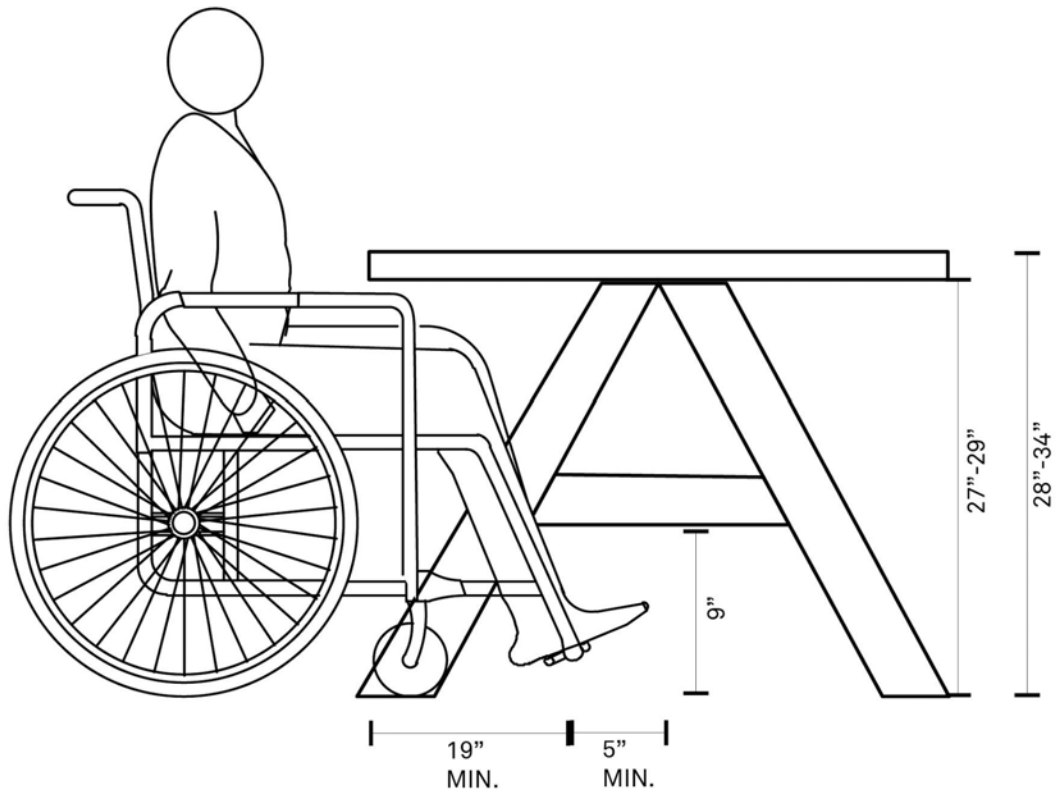

Figure 10 Side view of accessible picnic table height dimensions



Example of accessible table at Robert Clinkscales Playground and Community Garden

Sheds

Dimensions

According to NYC Department of Buildings, sheds in any community gardens should be “not more than 10 feet in height (greenhouses are limited to one story or 15 feet above the adjoining grade, whichever is less, as per Section 23-44(b) of NYC Zoning Code) not more than 150 square feet in area set back at least 6 feet from the lot line. For wheelchair access within a general shed, the doors must be at least 48.”

For more information on general shed requirements and foundations, see the NYC Parks GreenThumb Gardener’s Handbook³.

Entrance

For accessibility, the entrance into the tool shed should be flush with the ground or a ramp should be installed using the guidelines in the following section.

Inside the shed

Within the shed, there should be 5’ x 5’ unobstructed space inside to allow wheelchairs to make 360 degree turns.

Tools and workbench tops should be stored no higher than 44”-48” and no lower than 18”, reach depth should not exceed 20” with no obstruction in front.⁴

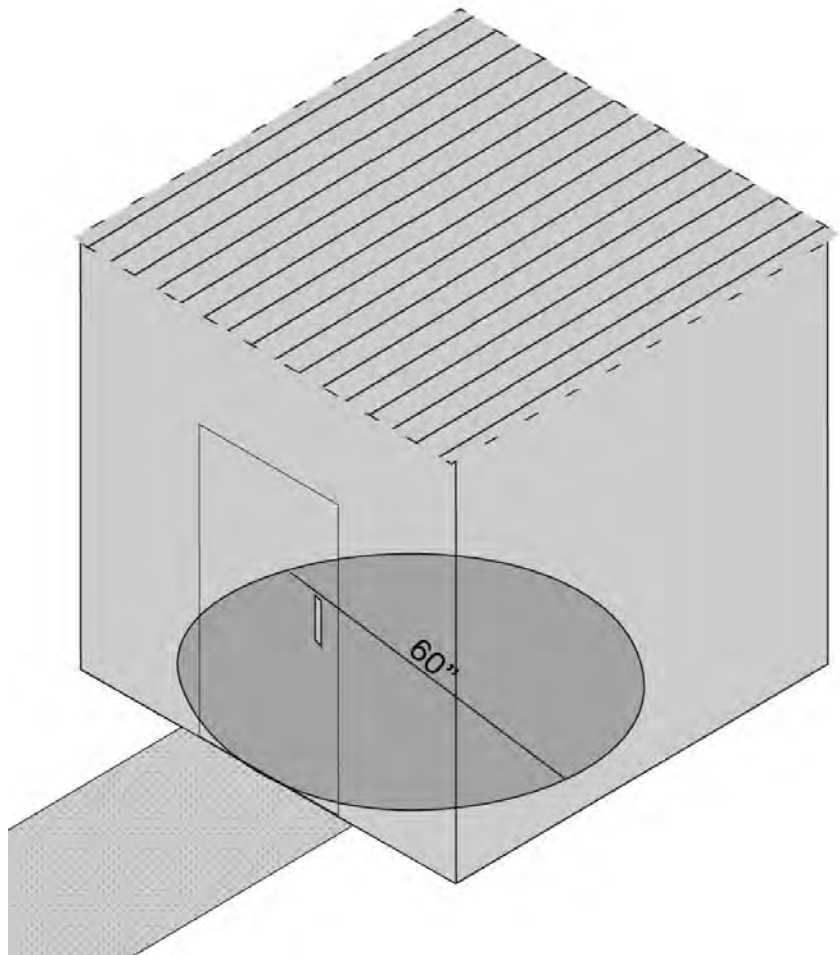

³ https://greenthumb.nycgovparks.org/pdf/GreenThumb_Gardeners_Handbook_2021.pdf

⁴ https://www.seattle.gov/Documents/Departments/Neighborhoods/PPatch/Tips/307_Accessible_Gardens.pdf

Shed Location

The tool shed should be located as close as possible to the accessible beds and have level, solid surface pathways leading to it.

Tool Shed Modifications

At a minimum there must be a way to store tools used at accessible beds, such as on hooks or special compartments as shown below.

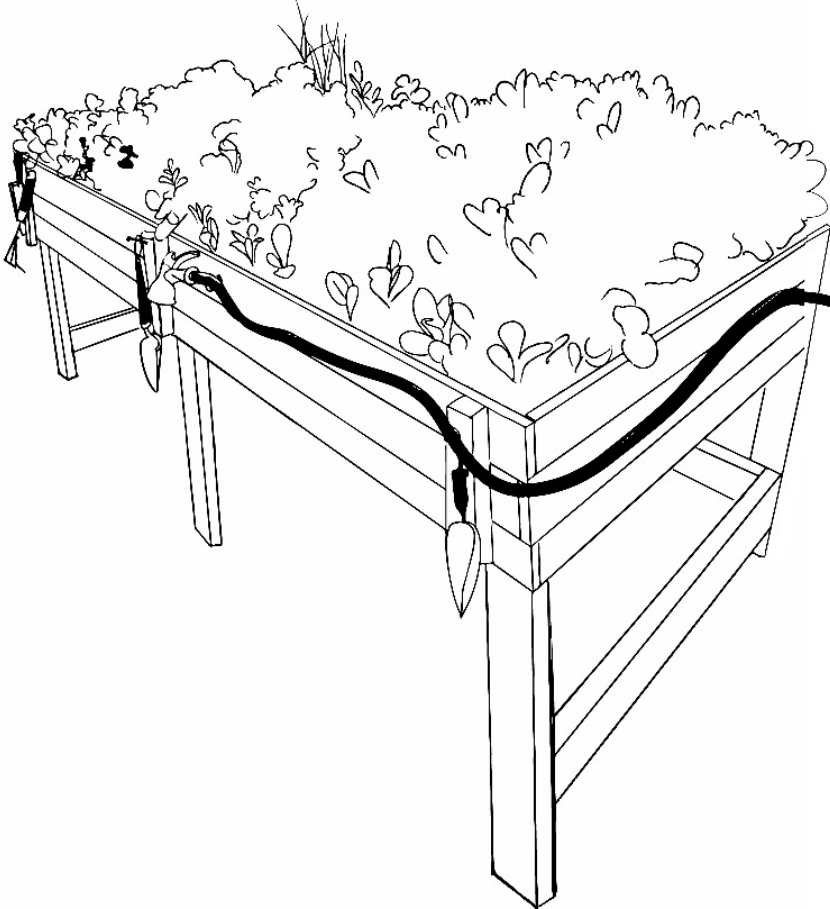

Ramps

Any sheds, gazebos, retaining walls, or other structures that are not flush must have a ramp to allow accessibility via wheelchair.

Ramps should:

- Be provided when a slope is steeper than 1:20
- Not be steeper than 1:12 (1' rise in 12") or 8.3% maximum.
- Not go longer than 30' (or rise 30") before a flat landing is created. A ramp with a slope between 1:16 and 1:20 can have a horizontal run up to 40'.
- Include a railing. For short runs, a 4" curb can be installed at the edge of a ramp.
- Be a minimum of 4' wide and follow slope requirements outlined in the "Slope" section above.
- Have a gravel or concrete foundation can be installed underneath to prevent sinking and ensure stability.

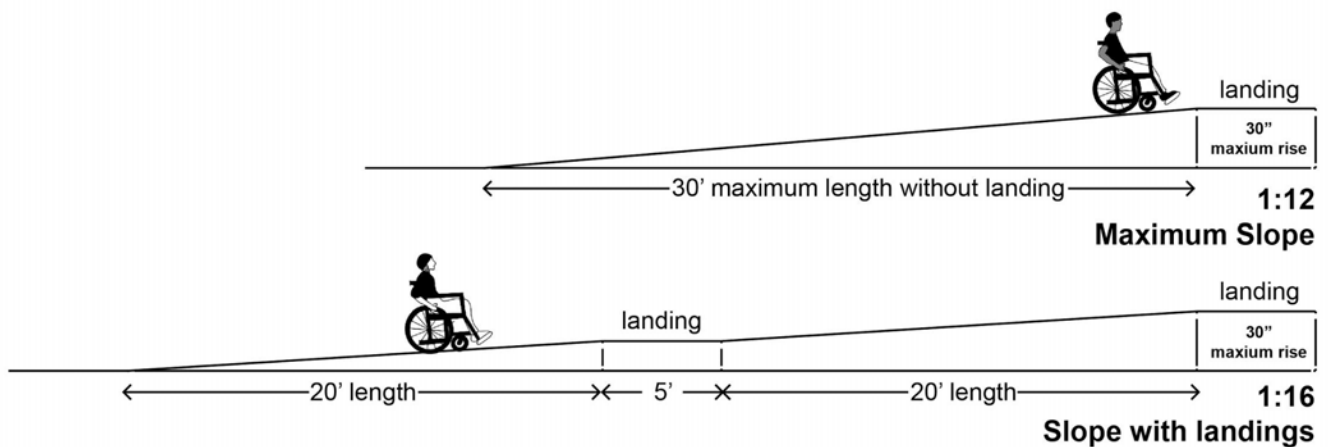

Handrails

The guidelines for handrails are explained here:

- Ramps should have handrails along both sides on any ramp system with a rise greater than 6" or a horizontal run greater than 72".
- The top surface to grip on to of any ramp handrail must be set at a height between 34"-38" above the ramp surface and a minimum clear width of 36" must be provided between handrails. The flooring of the ramp should not be slippery to ensure safety.
- In situations where a handrail is not continuous, handrails must extend at least another 12" parallel to the flat surface of the ramp landing.

A simple ramp can be created using lumber as shown in the diagram below:

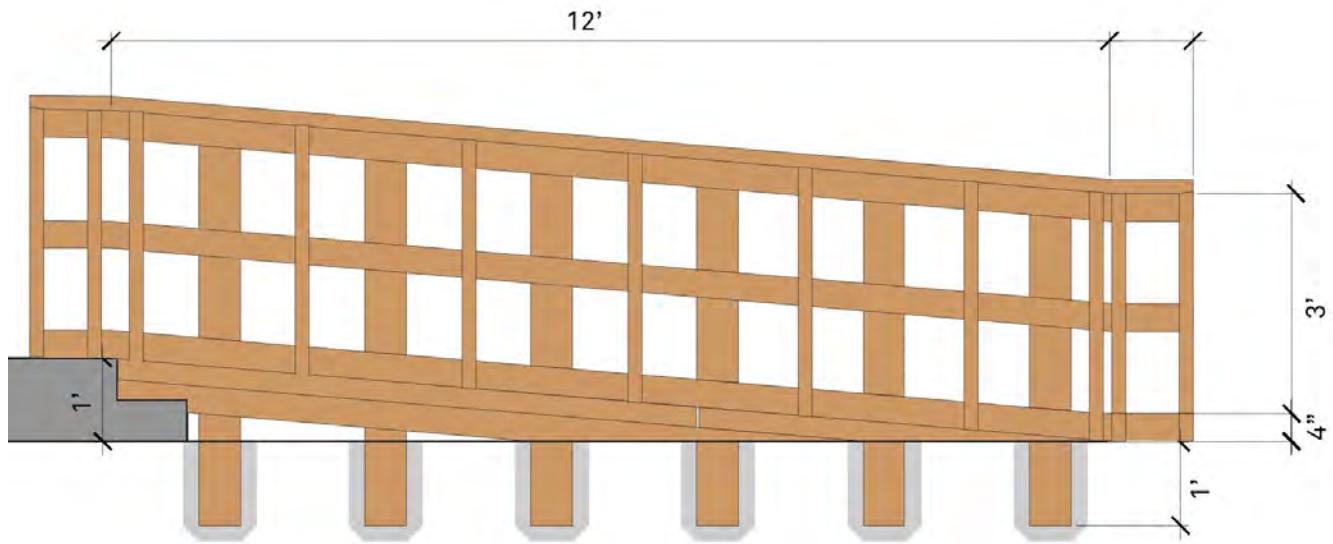

Irrigation

Accessible irrigation can include hand watering with watering cans, and drip systems which may also be automated. If hand watering, faucet handles should be easy to grip and turn with an accessible path leading to the source of water. Hoses should be lightweight but sturdy and kept in organizers or guards so that they do not block accessible paths. Hose organizers on wheels with wind up or retractable reels make hose storage easier. Watering wands attached to the ends of hoses can extend the reach to give gardeners more control over their watering. If watering cans are used, store cans in easy to access places, such as elevated on hooks or shelves. If using rainwater catchment systems, use platforms for tanks so that the spigot is 20"-34" off the ground to allow for comfortable access. Automated sprinklers, including drip systems, can make watering more universally accessible as well so that energy can be spent on other gardening tasks.⁵

Communication

A sign indicating accessible ramps, paths, and beds can be displayed to direct users to accessible garden features.

5

Examples of Accessible Gardens

Robert L. Clinkscales Playground and Community Garden

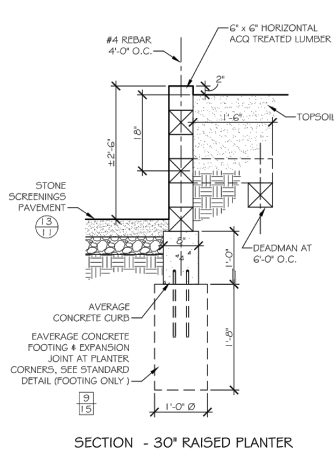

SECTION - 30" RAISED PLANTER

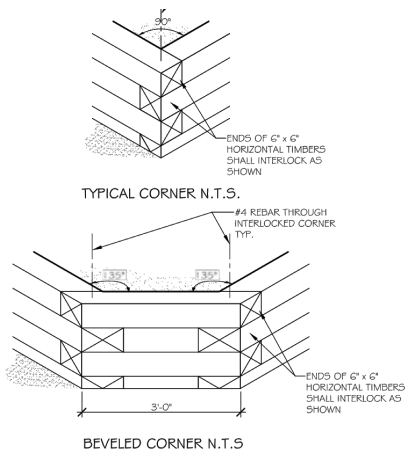

BEVELED CORNER N.T.S.

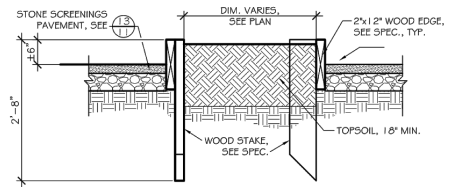

RAISED PLANTERS -
2"x10" WOOD EDGING
SCALE: 1" = 1'-0"

3 RAISED PLANTERS - 6"x6" LUMBER
SCALE: 1" = 1'-0"

4 RAISED PLANTERS -
2"x10" WOOD EDGING
SCALE: 1" = 1'-0"

A Better Community Garden

